

Bending

From rugged hand benders to the full-featured Smart Quad Bender™ which calculates complete layout measurements, Greenlee benders are the industry standard for bending EMT, IMC, PVC and rigid conduit. Refer to our easy-to-use selection guide for choosing a Greenlee bender or accessory that will get the job done right the first time.

Contents

Mechanical Benders	113
Electrical Benders	116
Hydraulic Benders	118
Accessories	125
PVC Heaters	128
PVC Accessories	130



MADE FOR THE TRADE!™



Bending Selection Guide

Combination Bending Rigid, EMT & IMC Conduit

CAT. NO. – DESCRIPTION	PAGE NO.	1/2"	3/4"	1"	1-1/4"	1-1/2"	2"	2-1/2"	3"	3-1/2"	4"	5"
1818 Mechanical Bender (EMT)	115		✓	✓	✓	✓	✓					
1818 Mechanical Bender (IMC)	115	✓	✓	✓	✓							
1818 Mechanical Bender (Rigid)	115	✓	✓	✓	✓	✓						
855 Smart Quad Bender™	116	✓	✓	✓	✓	✓	✓					
854 Quad Bender™	116	✓	✓	✓	✓	✓	✓					
555® Electric Bender Rigid & EMT*	117, 118	✓	✓	✓	✓	✓	✓					
555® Electric Bender IMC*	117, 118	✓	✓	✓	✓	✓	✓					
882 & 882CB Hydraulic Bender	118				✓	✓	✓					
881CT Hydraulic Bender	120							✓	✓	✓	✓	

*Correct shoe group required

Rigid Conduit Bending (Steel & Aluminum)

CAT. NO. – DESCRIPTION	PAGE NO.	1/2"	3/4"	1"	1-1/4"	1-1/2"	2"	2-1/2"	3"	3-1/2"	4"	5"
Hand Benders—SITE-RITE® Aluminum	113	841A	842A	843A								
Hand Benders—SITE-RITE® Iron	113	841F	842F	843F								
Hand Benders—Hickeys	113	508	512	516								
1800 Mechanical Bender	114	✓	✓	✓								
1801 Mechanical Bender	114				✓	✓						
* 1818 & 1818R Mechanical Bender	115	✓	✓	✓	✓	✓						
* 855 Smart Quad Bender™	116	✓	✓	✓	✓	✓	✓					
* 854 Quad Bender™	116	✓	✓	✓	✓	✓	✓					
* 555R/555RC Electric Bender	117	✓	✓	✓	✓	✓	✓					
882CB Hydraulic Bender	118				✓	✓	✓					
881CT Hydraulic Bender	120							✓	✓	✓	✓	
880 Hydraulic Bender	122		Optional	✓	✓	✓	✓					
777 Hydraulic Bender	123				✓	✓	✓	S	S	S	S	
884 Hydraulic Bender	124				✓	✓	✓	✓	✓	✓	✓	
885 Hydraulic Bender	124				✓	✓	✓	✓	✓	✓	✓	S

See notes below for Stainless Steel Rigid conduit bending.

EMT Conduit Bending

CAT. NO. – DESCRIPTION	PAGE NO.	1/2"	3/4"	1"	1-1/4"	1-1/2"	2"	2-1/2"	3"	3-1/2"	4"	5"
Hand Benders—SITE-RITE® Aluminum	113	840A	841A	842A	843A							
Hand Benders—SITE-RITE II® Iron	113	840F	841F	842F	843F							
† 1818 & 1818T Mechanical Bender	115		✓	✓	✓	✓	✓					
† 855 Smart Quad Bender™	116	✓	✓	✓	✓	✓	✓					
† 854 Quad Bender™	116	✓	✓	✓	✓	✓	✓					
† 555E/555EC Electric Bender	117	✓	✓	✓	✓	✓	✓					
882 & 882CB Hydraulic Bender	118				✓	✓	✓					
881CT Hydraulic Bender	120							✓	✓	✓	✓	

IMC Conduit Bending

CAT. NO. – DESCRIPTION	PAGE NO.	1/2"	3/4"	1"	1-1/4"	1-1/2"	2"	2-1/2"	3"	3-1/2"	4"	5"
Hand Benders—SITE-RITE® Aluminum	113	841A	842A	843A								
Hand Benders—SITE-RITE II® Iron	113	841F	842F	843F								
1800 Mechanical Bender	114	✓	✓	✓								
1801 Mechanical Bender	114				✓	✓						
1818 & 1818R Mechanical Bender	115	✓	✓	✓	✓							
855 Smart Quad Bender™	116	✓	✓	✓	✓	✓	✓					
854 Quad Bender™	116	✓	✓	✓	✓	✓	✓					
555I/555IC Electric Bender	117				✓	✓	✓					
882CB Hydraulic Bender	118				✓	✓	✓					
881CT Hydraulic Bender	120							✓	✓	✓	✓	

PVC Coated Rigid Conduit Bending

CAT. NO. – DESCRIPTION	PAGE NO.	1/2"	3/4"	1"	1-1/4"	1-1/2"	2"	2-1/2"	3"	3-1/2"	4"	5"
855 Smart Quad Bender™ with 01700 PVC Shoe Group	116	✓	✓	✓	✓	✓	✓					
854 Quad Bender™ with 01700 PVC Shoe Group	116	✓	✓	✓	✓	✓	✓					
555®/555C Electric Bender with 37279 Shoe Group	117	✓	✓	✓	✓	✓	✓					
884PVC Hydraulic Bender	124	Optional Shoes Required			✓	✓	✓	Optional	✓	Optional	✓	

✓ = One Shot Capability.
S = Segment Bend Only.
See pages 128 and 129 for PVC Blankets and Heaters for bending PVC.

* 1818, 1818R, 855, 854, 555 & 555C can also bend Stainless Steel Rigid conduit in the same size conduit ranges as steel Rigid conduit using the Rigid shoe group.

† 881CT can also bend 2-1/2" & 3" Stainless Steel Rigid Conduit using the respective 2-1/2" & 3" shoe groups.

† For Stainless Steel EMT conduit bending 855 & 854 can bend 1/2", 3/4", 1-1/2" & 2"; 555 & 555C can bend 1/2", 3/4" & 1-1/2"; and 1818 & 1818T can bend 3/4" & 1" with respective EMT shoe groups.

Bending

INTERNATIONAL

Tel: +1.815.397.7070
Fax: +1.815.397.9247

CANADA

Tel: 800.435.0786
Fax: 800.524.2853

USA

Tel: 800.435.0786
Fax: 800.451.2632

MECHANICAL BENDERS

SITE-RITE® Hand Benders for 1/2"-1 1/4" EMT and 1/2"-1" Rigid/IMC conduit

NEW



SITE-RITE® Aluminum Heads
840A, 841A, 842A, 843A



SITE-RITE® Iron Heads
840F, 841F, 842F, 843F

- Superior, patented Site-Rite® sighting system featuring cast-in, readable markings on the bender heads and a finish that provides for the best visibility in low-light.
- Choice of aluminum or iron alloy construction provides options depending on the user's preference for feel and weight.
- Strong, stable square hook design.
- 1-1/2" bender heads both offer the power pedal feature with a larger foot area on the head for greater control, stability and leverage.
- 1/2", 3/4" & 1" bender heads all have enlarged foot pedals and increased toe room to ensure greater control, stability and leverage.
- All the bender handles are a consistent diameter, offering a bigger grip area, while still straight up and down for fast 30 degree bends.
- Lifetime Limited Warranty.

CAT. NO.	UPC NO.	DESCRIPTION	WEIGHT
840A	12810	Aluminum Hand Bender Head for 1/2" EMT	1.4 lbs.(0.7 kg)
841A	12838	Aluminum Hand Bender Head for 3/4" EMT, 1/2" Rigid/IMC	2.1 lbs. (0.9 kg)
842A	12839	Aluminum Hand Bender Head for 1" EMT, 3/4" Rigid/IMC	3.5 lbs. (1.6 kg)
843A	12524	Aluminum Hand Bender Head for 1-1/4" EMT, 1" Rigid/IMC	8.3 lbs. (3.8 kg)
840AH	12676	Aluminum Hand Bender Head with Handle for 1/2" EMT*	5.5 lbs. (2.5 kg)
841AH	12677	Aluminum Hand Bender Head with Handle for 3/4" EMT, 1/2" Rigid/IMC*	6.4 lbs. (2.9 kg)
842AH	12678	Aluminum Hand Bender Head with Handle for 1" EMT, 3/4" Rigid/IMC*	11 lbs. (5 kg)
840F	12831	Iron Hand Bender Head for 1/2" EMT 1	3.1 lbs. (1.4 kg)
841F	12832	Iron Hand Bender Head for 3/4" EMT, 1/2" Rigid/IMC	4.3 lbs. (2.0 kg)
842F	12833	Iron Hand Bender Head for 1" EMT, 3/4" Rigid/IMC	7.2 lbs. (3.3 kg)
843F	12834	Iron Hand Bender Head for 1-1/4" EMT, 1" Rigid/IMC	16.2 lbs. (7.3 kg)
840FH	12835	Iron Hand Bender Head with Handle for 1/2" EMT*	7 lbs. (3.2 kg)
841FH	12836	Iron Hand Bender Head with Handle for 3/4" EMT, 1/2" Rigid/IMC*	9 lbs. (4.1 kg)
842FH	12837	Iron Hand Bender Head with Handle for 1" EMT, 3/4" Rigid/IMC*	15 lbs. (6.8 kg)
84H1	12689	Handle for 1/2" & 3/4" Aluminum or Iron Hand Bender Heads	4.5 lbs. (2.0 kg)
84H2	12690	Handle for 1" Aluminum or Iron Hand Bender Heads	7.3 lbs. (3.3 kg)
84H3	12691	Handle for 1-1/4" Aluminum or Iron Hand Bender Heads	11.5 lbs. (5.2 kg)

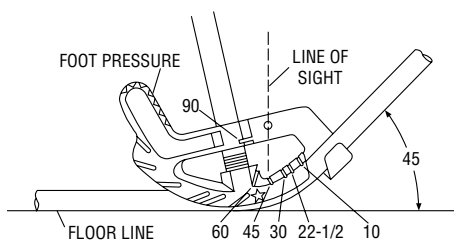

CENTERLINE BENDING RADII

EMT	RIGID IMC	CENTERLINE RADII	ALUMINUM	IRON
1/2"		4-3/16" (106.5 mm)	840A, 840AH	840F, 840FH
3/4"	1/2"	5-1/8" (130.2 mm)	841A, 841AH	841F, 841FH
1"	3/4"	6-1/2" (165.1 mm)	842A, 842AH	842F, 842FH
1-1/4"	1"	9-5/8" (244.5 mm)	843A	843F

HICKEYS with Welded Handles for 1/2" - 1" Rigid conduit



- Heavy-duty cast steel head.
- Welded steel handle.
- Bend tight radius stub-ups.

CAT. NO.	UPC NO.	DESCRIPTION	WEIGHT
508	18102	Hickey for 1/2" Rigid	6.9 lbs. (3.1 kg).
512	18103	Hickey for 3/4" Rigid	8 lbs. (3.6 kg).
516	18104	Hickey for 1" Rigid	13 lbs. (5.9 kg)

Bending

USA

Tel: 800.435.0786
Fax: 800.451.2632

CANADA

Tel: 800.435.0786
Fax: 800.524.2633

INTERNATIONAL

Tel: +1.815.397.7070
Fax: +1.815.397.9247

Little Kicker® Offset Bender



- Bends offsets in one easy operation. Insert conduit, depress handle, release and remove conduit.
- Makes identical offsets every time for wall mounted boxes with exposed conduit.
- Creates offset that matches the knockout in box.
- Maximum offset of .56" (9/16).

CAT. NO.	UPC NO.	DESCRIPTION
1810	13815	Offset Bender for 1/2" EMT
1811	14159	Offset Bender for 3/4" EMT



SPECIFICATIONS

Capacity	1810 – 1/2" EMT
	1811 – 3/4" EMT
Weight	1810 – 8.75 lbs. (4 kg)
	1811 – 8.50 lbs. (3.9 kg)

Mechanical Benders for IMC and Rigid Conduit



- Ratchet action for increased leverage.
- Bypass the ratchet for fast, direct bending on smaller sizes.
- Heavy-duty welded construction for long, reliable service.
- Built-in bending degree indicator and easy to use bending charts for accurate, consistent bends.
- Does not include handle.

CAT. NO.	UPC NO.	DESCRIPTION
1800	24400	Mechanical Bender for 1/2", 3/4", 1" IMC and Rigid conduit
1800G1	24401	Mechanical Bender without undercarriage, for bench or truck bed mounting. Bends 1/2", 3/4", 1" IMC and Rigid conduit
1801	24753	Mechanical Bender for 1-1/4", 1-1/2" IMC and Rigid conduit
08429	08429 	Undercarriage Unit for 1800 and 1801
19988	19988 	Wheel, Non-flat

Use a 5' (1.5 m) length of 1" Rigid conduit for the handle.

SPECIFICATIONS

Capacity	1800, 1800G1 – 1/2", 3/4" and 1" IMC and Rigid.
	1801, – 1-1/4" and 1-1/2" IMC and Rigid
Weight	1800 – 81 lbs. (36.7 kg)
	1800G1 – 48 lbs. (21.8 kg)
	1801 – 104 lbs. (47.2 kg)

CENTERLINE BENDING RADII

1800, 1800G1	1/2" Rigid conduit	2-5/8"	(66.7 mm)
	3/4" Rigid conduit	4-5/8"	(117.5 mm)
	1" Rigid conduit	5-7/8"	(149.2 mm)
1801	1-1/4" Rigid conduit	8-1/16"	(204.8 mm)
	1-1/2" Rigid conduit	9-11/16"	(246.1 mm)

Mechanical Benders for EMT, IMC, Rigid and Aluminum Conduit



- Bends a wide variety of types and sizes of conduit.
- Durable ratchet mechanism for easy bending.
- Bypass the ratchet for fast, direct bending on smaller sizes.
- Bending degree indicator and charts for fast, easy, accurate bending.
- All shoe and bending accessories can be mounted to the frame unit and secured with a chain and lock.
- Heavy-duty undercarriage with wheels.
- Does not include handle.

SPECIFICATIONS

Capacity	EMT: 3/4" - 2"	STAINLESS STEEL RIGID:
	RIGID: 1/2" - 1-1/2"	1/2" - 1-1/2"
	IMC: 1/2" - 1-1/4"	STAINLESS STEEL EMT:
	ALUMINUM RIGID: 1/2" - 1-1/2"	3/4" - 1"
Weight	1818 - 250 lbs. (114 kg)	
	1818T - 217 lbs. (99 kg)	
	1818R - 185 lbs. (84 kg)	

CAT. NO.	UPC NO.	DESCRIPTION
1818	22192	Mechanical Bender for 3/4" through 2" EMT conduit, 1/2" through 1-1/4" IMC conduit and 1/2" through 1-1/2" Rigid steel, aluminum and stainless steel conduit
1818R	20231	Mechanical Bender for 1/2" through 1-1/4" IMC conduit and 1/2" through 1-1/2" Rigid steel, aluminum and stainless steel conduit
1818T	20232	Mechanical Bender for 3/4" through 2" EMT conduit and 3/4" & 1" stainless steel EMT
08429	08429	Under Carriage Assembly
1818G1	22220 R	Frame and undercarriage unit only
19988	19988 R	Wheel, Non-flat

KEY	CAT NO.	UPC NO.	DESCRIPTION	BENDERS				SHOE GROUPS*		
				1818	1818R	1818T	1818G1	36905	36906	36907
A	1818G1	22220	Frame and Undercarriage Unit	1	1	1	1			
B	36697	36697	Roller Pin Unit	1	1	1		1	1	1
C	18681	18681	Cushioned Roller Unit	1	1	1		1	1	1
D	18827	18827	1/2, 3/4 & 1" Rigid/IMC Shoe Unit	1	1			1	1	
E	18828	18828	1-1/4" Rigid/IMC; 1-1/2" Rigid Shoe Unit	1	1			1	1	
G	18830	18830	3/4 & 1" EMT Shoe Unit	1		1		1		1
H	18831	18831	1-1/4 & 1-1/2" EMT Shoe Unit	1		1		1		1
I	18642	18642	1-1/4 & 1-1/2" EMT Follow Bar	1		1		1		1
J	18832	18832	2" EMT Shoe Unit	1		1		1		1
K	18636	18636	2" EMT Follow Bar	1		1		1		1
L	36296	36296	Roller Follow Bar Guide	1		1		1		1
N	18772	18772	Retainer Clip	1	1	1		1	1	1
O	19988	19988	Wheel, Non-flat	2	2	2				
F	18829 1723	18829 23818	2" Rigid Aluminum Shoe Unit Steel Storage Box For Shoe Units	OPTIONAL						

* SHOE GROUPS Reference chart for ordering bending accessories.

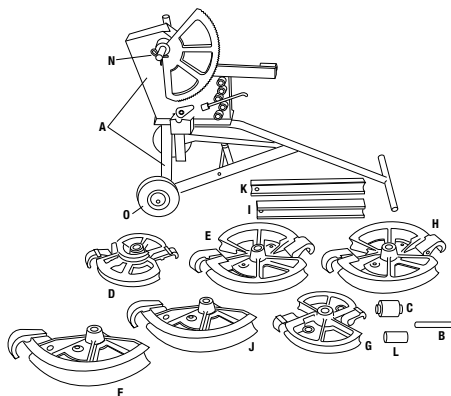

N = NEW PRODUCT **R** = REPLACEMENT PART **A** = ACCESSORY

CENTERLINE BENDING RADII

SHOE SIZE	INCHES	mm
1/2" Rigid/IMC	2-21/32"	67.5
3/4" Rigid/IMC	4-5/8"	117.5
3/4" EMT	5-3/32"	129.4
1" Rigid/IMC	5-7/8"	149.2
1" EMT	6-13/32"	162.7
1-1/4" Rigid/IMC	7-3/8"	187.3
1-1/4" EMT	8-9/32"	210.3
1-1/2" Rigid	9"	228.6
1-1/2" EMT	8-9/32"	210.3
2" EMT	9-3/16"	233.4
2" Aluminum	10-15/32"	265.9

Bending

USA

Tel: 800.435.0786
Fax: 800.451.2632

CANADA

Tel: 800.435.0786
Fax: 800.524.2653

INTERNATIONAL

Tel: +1.815.397.7070
Fax: +1.815.397.9247

ELECTRICAL BENDERS

Smart Quad Bender[™] Electric Conduit Bender for 1/2" to 2" EMT, IMC, Rigid and Rigid Aluminum



01711 - Deluxe Pendant

- Bends a variety of types and sizes of conduit.
- Intelligent pendant controls: Standard (included), digital readout and programmable bend angles for accurate repeat bends. Deluxe (optional), interactive control – calculates complete layout measurements for various types of bends.
- Bends 1/2" to 2" EMT, IMC, Rigid and Rigid aluminum conduit without any shoe changes. No loose parts to get lost.
- Two operating positions; table top and upright.
- Optional shoes available to bend PVC-coated steel conduit.
- Excellent portability. Convenient lifting eyes and fork tubes.
- Weather-resistant construction.
- Squeeze adjustment to compensate for variations in EMT conduit.

CAT. NO. UPC NO. DESCRIPTION

855	08550	Smart Bender for 1/2" - 2" EMT, IMC and Rigid conduit (Includes Standard Pendant)
38650	38650	A Deluxe Pendant for older bender with serial code ZW
01711	01711	A Deluxe Pendant for current bender with serial code ABL & ADY
38863	38863	B Standard Pendant for older bender with serial code ZW
01648	01648	B Standard Pendant for current bender with serial code ABL & ADY
38780	38780	R Shoe Unit, 1/2" - 1-1/4"
38148	38148	R Shoe Unit, 1-1/2" - 2"
01700	01700	A 40 MIL PVC Coated Rigid Shoe Group, 1/2"-2" (Exc. ZW)
38962	38962	A Vinyl Rain Cover

SPECIFICATIONS

Capacity	1/2" - 2" EMT, IMC, Rigid and Rigid Aluminum conduit
Power Source	120 VAC; 20 Amp
Weight	510 lbs. (231.3 kg)

Quad Bender[™] Electric Conduit Bender for 1/2" to 2" EMT, IMC, and Rigid Aluminum



- Bends 1/2" to 2" EMT, IMC, Rigid and Rigid Aluminum conduit without any shoe changes. No loose parts to get lost.
- Two operating positions; tabletop and upright.
- Remote pendant switch and bending data charts for easy, accurate bends.
- Simple setup and easy operation.
- Squeeze adjustment to compensate for variations in EMT conduit.
- Excellent portability. Convenient lifting eyes and fork tubes.
- Optional shoes available to bend PVC coated steel conduit.

CAT. NO. UPC NO. DESCRIPTION

854	03106	Quad Bender for 1/2" - 2" EMT, IMC, Rigid and Rigid Aluminum, conduit
38780	38780	B Shoe Unit, 1/2" - 1-1/4"
38148	38148	R Shoe Unit, 1-1/2" - 2"
01700	01700	A 40 MIL PVC Coated Rigid Shoe Group, 1/2"-2"

SPECIFICATIONS

Capacity	1/2" - 2" EMT, IMC, Rigid and Rigid Aluminum conduit
Power Source	120 VAC; 20 Amp
Weight	510 lbs. (231.3 kg)

CENTERLINE BENDING RADII

SHOE SIZE	INCHES	mm	SHOE SIZE	INCHES	mm	SHOE SIZE	INCHES	mm
1/2" EMT	4-5/16"	109.5	1" EMT	7"	177.8	1-1/2" EMT	8-3/8"	212.7
1/2" IMC/Rigid	4-1/4"	108.0	1" IMC/Rigid	6-15/16"	176.2	1-1/2" IMC/Rigid	8-1/4"	209.6
3/4" EMT	5-1/2"	139.7	1-1/4" EMT	8-13/16"	223.8	2" EMT	9-1/4"	235.0
3/4" IMC/Rigid	5-7/16"	138.1	1-1/4" IMC/Rigid	8-3/4"	222.3	2" IMC/Rigid	9"	228.6

Bending

INTERNATIONAL

Tel: +1.815.397.7070
Fax: +1.815.397.9247

CANADA

Tel: 800.435.0786
Fax: 800.524.2853

USA

Tel: 800.435.0786
Fax: 800.451.2632

555® Series Electric Conduit Benders for 1/2" through 2" Conduit and Pipe



No Flat Tires



555RC Classic

- Available in four models for Rigid, EMT or IMC conduit, or bender only without shoes.
- The optional PVC-coated Rigid conduit shoe group can be used on all 555 series benders.

Deluxe Only

- 555 Deluxe Series features unique electrical controls that reduce the in-rush current to the relays to minimize contact arcing for longer life, heavy-duty no flat pneumatic tires and UL/ULC approved.

Classic Only

- The 555C Classic Series features simple relay controls for easy field repairs, and compact handle design to prevent interference with conduit when bending.

CAT. NO.	UPC NO.	DESCRIPTION
555	39780	Deluxe Electric Bender power unit without bending accessories
555R	23446	Deluxe Electric Bender with Shoe Group for 1/2" through 2" Rigid and 1/2" through 1-1/4" IMC conduit and pipe includes 28007 - 1/2" - 2" Rigid Shoe Group
555E	27989	Deluxe Electric Bender with Shoe Group for 1/2" through 2" EMT conduit includes 23802 - 1/2" - 2" EMT Shoe Group
555I	27990	Deluxe Electric Bender with Shoe Group for 1-1/2" through 2" IMC conduit includes 26330 - 1-1/2" - 2" IMC Shoe Group
555-22	39971	220 VAC 50/60 Cycle Deluxe Electric Bender power unit without bending accessories
555R-22	07145	220 VAC 50/60 Cycle Deluxe Electric Bender power unit with Shoe Group for 1/2" through 2" Rigid and 1/2" through 1-1/4" IMC conduit and pipe includes 28007 - 1/2" - 2" Rigid Shoe Group
555C	06900	Classic Electric Bender power unit without bending accessories
555RC	06901	Classic Electric Bender with Shoe Group for 1/2" through 2" Rigid and 1/2" through 1-1/4" IMC conduit and pipe; includes 28007 - 1/2" - 2" Rigid Shoe Group
555EC	06902	Classic Electric Bender with Shoe Group for 1/2" through 2" EMT conduit includes 23802 - 1/2" - 2" EMT Shoe Group
555IC	06903	Classic Electric Bender with Shoe Group for 1-1/2" through 2" IMC conduit includes 26330 - 1-1/2" - 2" IMC Shoe Group
37279	37279	A 40 MIL PVC Coated Rigid 1/2" - 2" Shoe Group (sold separately) to use with the 555 series benders
53389	53389	A PIN-HITCH .437x8.10 - Weight .39

SPECIFICATIONS

Capacity	555R/555RC: 1/2" - 2" Rigid and 1/2" - 1-1/4" IMC conduit 555E/555EC: 1/2" - 2" EMT conduit 555I/555IC: 1-1/2" and 2" IMC conduit
Power Source	555 Deluxe Series: 120 VAC; 20 Amp GFCI-protected receptacle 555-22/555R-22: 220 VAC 50/60 Cycle; 20 Amp GFCI-protected receptacle 555C Classic Series: 120 VAC; 20 amp GFCI-protected receptacle
Operating Temperature	-5° F to 120° F (-20° C to 49° C)
Relative Humidity	0-98%
Weight	555/555C: 260 lbs. (118 kg) 555R/555RC: 393 lbs. (179 kg) 555E/555EC: 476 lbs. (216 kg) 555I/555IC: 456 lbs. (207 kg)
Height	555 Deluxe Series: 44" (1118 mm)
Width	555 Deluxe Series: 29-5/8" (753 mm)
Depth	555 Deluxe Series: 28-1/2" (724 mm)

555 CENTERLINE BENDING RADII

SHOE SIZE	EMT	RIGID	IMC
1/2"	4-1/4" (10.80 cm)	4-1/4" (108 mm)	4-1/4" (108 mm)
3/4"	5-3/8" (13.65 cm)	5-7/16" (138 mm)	5-7/16" (138 mm)
1"	6-3/4" (17.15 cm)	6-5/16" (176 mm)	6-5/16" (176 mm)
1-1/4"	8-3/4" (22.22 cm)	8-3/4" (222 mm)	8-3/4" (222 mm)
1-1/2"	8-9/32" (21.03 cm)	8-1/4" (209 mm)	8-9/32" (210 mm)
2"	9-3/16" (23.33 cm)	9-1/2" (241 mm)	9-3/16" (233 mm)

555[®] Accessory Shoe Groups

23802 1/2" - 2" EMT SHOE GROUP CONSISTS OF ONE EACH:

KEY	CAT. NO.	UPC NO.	DESCRIPTION
1	17944	17944	1/2" through 1-1/4" EMT Bending Shoe
2	17986	17986	1/2" through 1-1/4" Support Roller
3	23499	23499	1-1/2" EMT Bending Shoe
4	23505	23505	2" EMT Bending Shoe
5	23541	23541	1-1/2" through 2" Roller Support Unit
	1723	23818	Metal Storage Box (not shown)

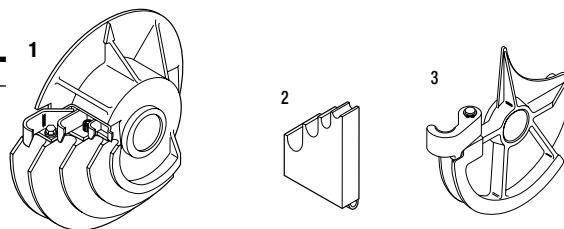

23816 1-1/2" AND 2" EMT SHOE GROUP CONSISTS OF ONE EACH:

KEY	CAT. NO.	UPC NO.	DESCRIPTION
3	23499	23499	1-1/2" EMT Bending Shoe
4	23505	23505	2" EMT Bending Shoe
5	23541	23541	1-1/2" through 2" Roller Support Unit

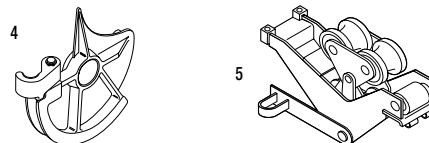

26330 1-1/2" AND 2" IMC SHOE GROUP CONSISTS OF ONE EACH:

KEY	CAT. NO.	UPC NO.	DESCRIPTION
6	25263	25263	1-1/2" IMC Bending Shoe
7	25268	25268	2" IMC Bending Shoe
8	25273	25273	1-1/2" through 2" Roller Support Unit
	1723	23818	Metal Storage Box (not shown)

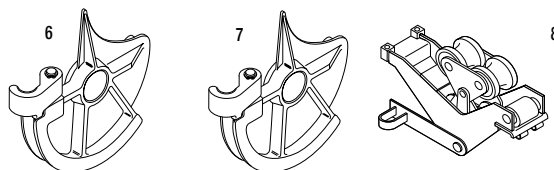

28007 1/2" - 2" RIGID SHOE GROUP CONSISTS OF ONE EACH:

KEY	CAT. NO.	UPC NO.	DESCRIPTION
9	00571	00571	1/2" through 1-1/4" Rigid/IMC Bending Shoe
10	00936	00936	1/2" through 1-1/4" Support Roller
11	17937	17937	1-1/2" through 2" Rigid Bending Shoe
12	17984	17984	1-1/2" through 2" Support Roller

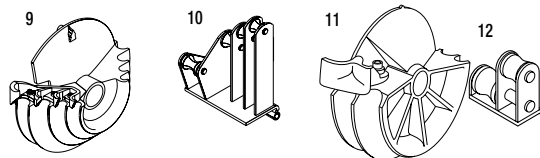

37279 40 MIL PVC COATED RIGID 1/2" - 2" SHOE GROUP CONSISTS OF ONE EACH:

KEY	CAT. NO.	UPC NO.	DESCRIPTION
13	00946	00946	1/2" through 1-1/4" Roller Support
14	00573	00573	1/2" through 1-1/4" Shoe
15	37281	37281	1-1/2" and 2" Shoe
16	37282	37282	1-1/2" through 2" Roller Support
	1723	23818	Metal Storage Box (not shown)

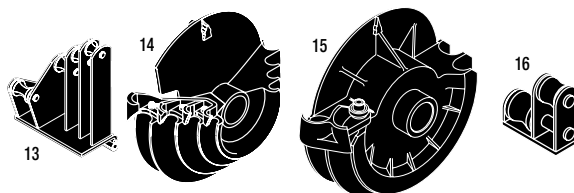

To use the PVC Shoe Group with 555 SB and 555 SBR benders Adapter Set 32391 is required.

HYDRAULIC BENDERS

Flip-Top[®] Benders for 1-1/4" - 2" EMT, IMC and Rigid



- Choose 882 for EMT or 882CB models for EMT, IMC and Rigid Conduit.
- Simple, accurate and easy to use.
- Flip-Top hinged frame top plate opens for easy, fast loading and unloading.
- Ram travel scale and charts for accurate bends, offsets and saddles.

CAT. NO.	UPC NO.	DESCRIPTION
882	15128	Flip-Top Bender for 1-1/4", 1-1/2" and 2" EMT Conduit without Hydraulic Pump
882CB	29536	Flip-Top Bender with shoes for 1-1/4", 1-1/2" and 2" EMT, IMC and Rigid Conduit without Hydraulic Pump
882CBH755	29537	Flip-Top Bender with shoes for 1-1/4", 1-1/2" and 2" EMT, IMC and Rigid Conduit with 755 Hand Hydraulic Pump
882CBE975	34202	Flip-Top Bender with shoes for 1-1/4", 1-1/2" and 2" EMT, IMC and Rigid Conduit with 975 Electric Hydraulic Pump
882H755	16460	Flip-Top Bender for 1-1/4", 1-1/2" and 2" EMT Conduit with 755 Hand Hydraulic Pump
882E975	34201	Flip-Top Bender for 1-1/4", 1-1/2" and 2" EMT Conduit with 975 Electric Hydraulic Pump
882RIG1	29948	A Conversion Attachment Set - Converts 882 to 882CB by adding the shoes, follow bars and saddles for 1-1/4", 1-1/2" and 2" IMC and Rigid Conduit

SPECIFICATIONS

Capacity	Weight
882-1-1/4", 1-1/2" and 2" EMT	882-141 lbs (64 kg)
882CB-1-1/4", 1-1/2" and 2" EMT, IMC and Rigid	882H755- 161 lbs (73 kg)
Power Source	882CBH755- 217 lbs (99 kg)
755- Hydraulic Hand Pump	882CBE975- 264 lbs (120 kg)
975- 120 VAC Electric Hydraulic Pump	882E975- 195 lbs (89 kg)
976-22PS- 220 VAC 50/60 Cycle Electric Hydraulic Pump	882CB- 205 lbs (93 kg)

FLIP-TOP[®] BENDER CENTERLINE BENDING RADII

SIZE	882, 882CB		882CB	
	EMT	RIGID	EMT	IMC
1-1/4"	7-7/32" (183.4 mm)	7-1/4" (184.2 mm)	7-1/4" (184.2 mm)	7-1/4" (184.2 mm)
1-1/2"	8-1/16" (204.8 mm)	8-1/4" (209.5 mm)	8-1/4" (209.5 mm)	8-1/4" (209.5 mm)
2"	9-5/16" (236.5 mm)	8-7/8" (225.4 mm)	8-7/8" (225.4 mm)	8-7/8" (225.4 mm)

Bending

INTERNATIONAL

Tel: +1.815.397.7070
Fax: +1.815.397.9247

CANADA

Tel: 800.435.0786
Fax: 800.524.2853

USA

Tel: 800.435.0786
Fax: 800.451.2632

Flip-Top® Benders and Shoe Groups

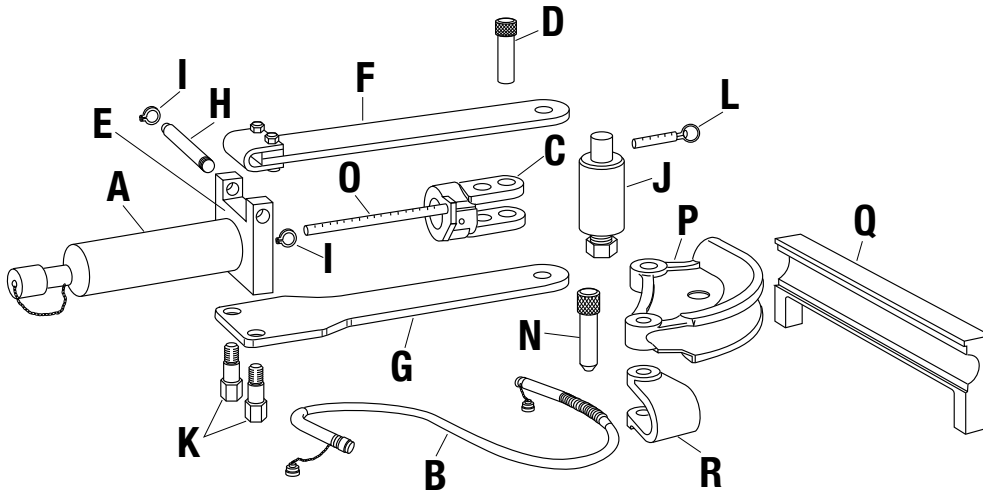

KEY	CAT NO.	UPC NO.	DESCRIPTION	BENDERS		SHOE GROUP
				882	882CB	882RIG1
A	1738	15129	12-Ton Hydraulic Ram with 4018GB female quick Coupler	1	1	
B	11289	11289	3/8" x 6' (9.5 x 1829 mm) Hydraulic Hose with two 4033GB male quick couplers	1	1	
C	15145	15145	Yoke	1	1	
D	04086	04086	Yoke Pin	1	1	
E	16563	16563	Frame Unit (includes F thru K)	1	1	
F	15136	15136	Upper Connecting Plate Unit	1	1	
G	15135	15135	Lower Connecting Plate Unit	1	1	
H	15150	15150	Hinge Pin	1	1	
I	50283	50283	Retaining Ring	2	2	
J	38778	38778	Roller Unit with pin (L)	1	1	
K	15147	15147	Anchor Stud	2	2	
L	54303	54303	Hitch Pin, 3/8 x 1-1/2	1	1	
N	29937	29937	Saddle Pin	1	1	1
O	50848	50848	Scale Jam Nut			
O	52867	52867	Scale O-Ring			
O	21954	21954	Scale Piston	1	1	
	1531	23274	Steel Storage Box (not shown)	1	1	
P	11146	11146	1-1/4" EMT Shoe	1	1	
Q	11126	11126	1-1/4" EMT Follow Bar	1	1	
R	11075	11075	1-1/4" EMT Saddle	1	1	
P	14287	14287	1-1/2" EMT Shoe	1	1	
Q	11107	11107	1-1/2" EMT Follow Bar	1	1	
R	11072	11072	1-1/2" EMT Saddle	1	1	
P	11132	11132	2" EMT Shoe	1	1	
Q	11089	11089	2" EMT Follow Bar	1	1	
R	14279	14279	2" EMT Saddle	1	1	
P	29474	29474	1-1/4" IMC and Rigid Shoe		1	1
Q	29477	29477	1-1/4" IMC and Rigid Follow Bar		1	1
R	29465	29465	1-1/4" IMC and Rigid Saddle		1	1
P	29470	29470	1-1/2" IMC and Rigid Shoe		1	1
Q	29472	29472	1-1/2" IMC and Rigid Follow Bar		1	1
R	29464	29464	1-1/2" IMC and Rigid Saddle		1	1
P	29466	29466	2" IMC and Rigid Shoe		1	1
Q	29468	29468	2" IMC and Rigid Follow Bar		1	1
R	29463	29463	2" IMC and Rigid Saddle		1	1

Bending

USA

Tel: 800.435.0786
Fax: 800.451.2632

CANADA

Tel: 800.435.0786
Fax: 800.524.2653

INTERNATIONAL

Tel: +1.815.397.7070
Fax: +1.815.397.9247

Cam Track[®] Conduit Benders for 2-1/2" to 4" EMT, IMC and Rigid

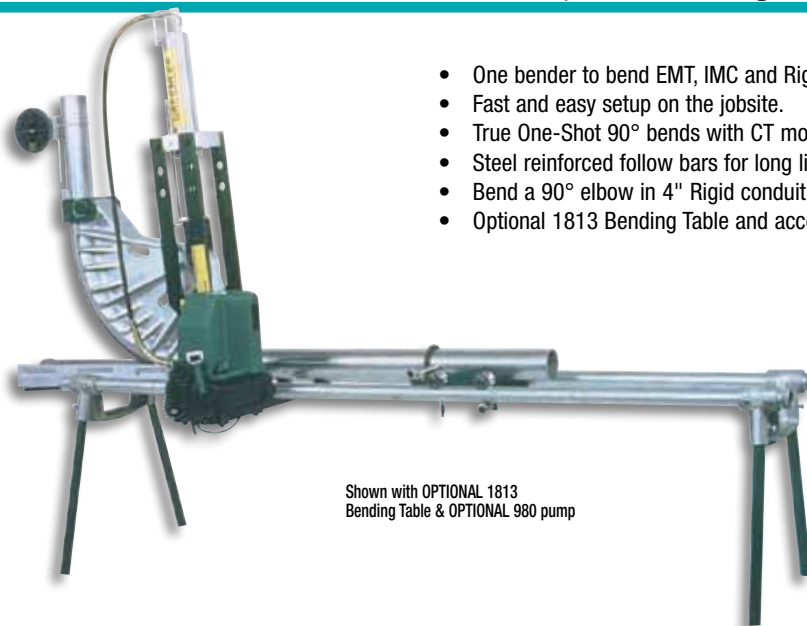

Shown with OPTIONAL 1813 Bending Table & OPTIONAL 980 pump

- One bender to bend EMT, IMC and Rigid Conduit.
- Fast and easy setup on the jobsite.
- True One-Shot 90° bends with CT models for quick accurate bends.
- Steel reinforced follow bars for long life.
- Bend a 90° elbow in 4" Rigid conduit in 95 seconds.
- Optional 1813 Bending Table and accessories for easier operation.

SPECIFICATIONS

Capacity	2-1/2" - 4" EMT, IMC and Rigid
Power Source	980: 120 VAC Electric Powered Hydraulic Pump 980-22PS: 220 VAC 50/60 Cycle Electric Powered Hydraulic Pump
Weight	881CTE980: 999 lbs. (454 kg) 881CTDE980: 1026 lbs. (465 kg) 881 BASIC: 358 lbs. (163 kg) 27555: 137 lbs. (62 kg) 31274: 183 lbs. (83 kg)

CAM TRACK[®] BENDER CENTERLINE BENDING RADII FOR EMT, IMC AND RIGID CONDUIT

SIZE	881 CT, 881 CTD, 881 BASIC		
	CENTERLINE RADIUS	SHOE GROUP	DEGREE OF BEND
2-1/2"	13-1/2" (342.9 mm)	27554	90
3"	16" (406.4 mm)	27555	90
3-1/2"	18-5/8" (473.1 mm)	31281	90
4"	20-7/8" (530.2 mm)	31274	90

CAT. NO. UPC NO. DESCRIPTION

CAT. NO.	UPC NO.	DESCRIPTION
881CT	31287	Cam Track Conduit Bender for One-Shot 90° Bends in 2-1/2", 3", 3-1/2" and 4" EMT, IMC and Rigid conduit, without hydraulic pump
881CTE980	34208	Cam Track Conduit Bender for One-Shot 90° Bends in 2-1/2", 3", 3-1/2" and 4" EMT, IMC and Rigid conduit, with 980 Electric Hydraulic Pump
881CTD	38466	Cam Track Conduit Bender for One-Shot 90° Bends in 2-1/2", 3" and 4" EMT, IMC and Rigid conduit, without hydraulic pump & 3-1/2" shoe group
881CTDE980	38467	Cam Track Conduit Bender for One-Shot 90° Bends in 2-1/2", 3" and 4" EMT, IMC and Rigid conduit, with 980 Electric Hydraulic Pump, without 3-1/2" shoe group
881BASIC	35711	Conduit Bender without shoe groups or hydraulic pump
27554	27554	A 2-1/2" - One-Shot 90° EMT, IMC, Rigid Shoe Group
27555	27555	A 3" - One-Shot 90° EMT, IMC, Rigid Shoe Group
31281	31281	A 3-1/2" - One-Shot 90° EMT, IMC, Rigid Shoe Group
31274	31274	A 4" - One-Shot 90° EMT, IMC, Rigid Shoe Group
1813	28901	A Bending Table for 881 Bender

Cam Track[®] Benders and Shoe Groups

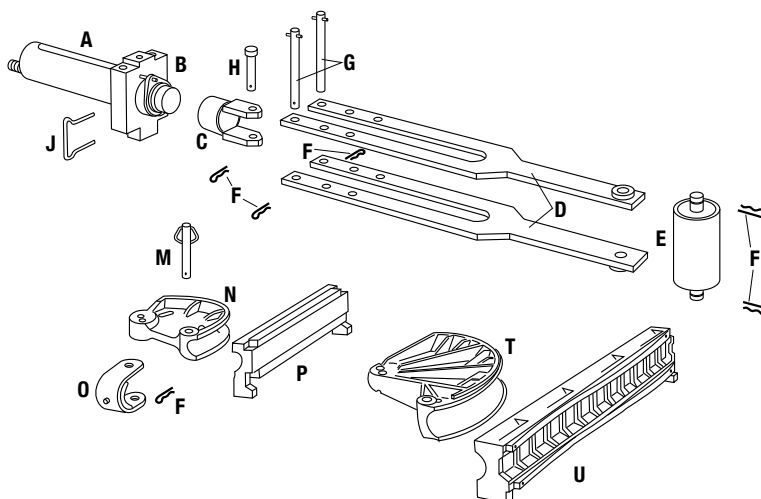

KEY	CAT. NO.	UPC NO.	DESCRIPTION	BENDERS			SHOE GROUPS			
				881BASIC	881CT	881CTD	27554	27555	31281	31274
A	27416	27416	40-Ton Hydraulic Ram with 4018GB female quick coupler. The ram includes Keys B, G, and two clips from Key F.	1	1	1				
B	27417	27417	Cylinder Block	1	1	1				
C	30309	30309	Yoke	1	1	1				
D	26309	26309	Connecting Bar Unit	2	2	2				
E	27364	27364	Roller Unit-The roller unit includes two clips from Key F	1	1	1				
F	50302	50302	Hitch Pin Clips	6	6	6				
G	27381	27381	Cylinder Block Pin Unit	2	2	2				
H	26306	26306	Yoke Pin	1	1	1				
J	26349	26349	Spring Clip (secures Yoke Unit to Ram)	1	1	1				
	11289	11289	3/8" x 6' (9.5 x 1829 mm) Hydraulic Hose with two 4033GB male quick couplers	1	1	1				
M	26624	26624	Saddle Pin Unit - includes 1 clip from Key F	1	1	1				
N	26297	26297	2-1/2" Shoe 90°		1	1	1			
P	26366	26366	2-1/2" Follow Bar 90°		1	1	1			
O	26580	26580	2-1/2" Saddle		1	1	1			
N	26300	26300	3" Shoe 90°		1	1		1		
P	35400	35400	3" Follow Bar 90°		1	1		1		
O	26584	26584	3" Saddle		1	1		1		
O	26588	26588	3-1/2" Saddle		1				1	
T	31882	31882	3-1/2" Shoe 90°		1				1	
U	31881	31881	3-1/2" Follow Bar 90°		1				1	
O	26594	26594	4" Saddle		1	1				1
T	31884	31884	4" Shoe 90°		1	1				1
U	31883	31883	4" Follow Bar 90°		1	1				1
	2460	23363	Steel Storage Box (not shown)	1	1	1				
	695	30239	Caster Set (not shown)	1	1	1				

Bending Table (only) for 881 & 881CT Benders

- Converts the 881 Bender into a comfortable, bench-high machine . . . reduces operator fatigue . . . makes loading faster, easier.
- Offset and one-shot bends in all three types of conduit are made quickly and easily with consistent accuracy.
- Pipe vise holds conduit securely for accurate bends. Prevents conduit from twisting or turning during bend.
- Includes 1805 Bending Degree Protractor and metal storage box.

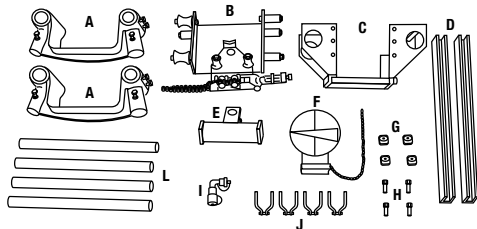

CAT. NO.	UPC NO.	DESCRIPTION	WEIGHT
1813	28901	Bending Table for 881 & 881CT Bender	186 lbs (85 kg)

PARTS

KEY	CAT. NO.	UPC NO.	DESCRIPTION	1813/ 28901
A	21541	21541	Leg Support Unit	2
B	28900	28900	Carriage Unit w/vise	1
C	28885	28885	Bender Mounting Unit	1
D	29004	29004	Pump Table Support	2
E	29022	29022	Ram Positioner	1
F	1805	21318	Bending Degree Protractor	1
G	53824	53824	Pump Bracket	4
H	51185	51185	Pump Mounting Screw	4
I	29014	29014	90° Coupling Unit	1
J	53014	53014	Steel Conduit Clamp	4
L	21346	21346	Legs	4
	1531	23274	Steel Storage Box (not shown)	1
	51593	51593	Hex Nut	4
	50975	50975	Cap Screw	4
	51674	51674	Washer	4

Rigid Conduit Bender for 1/2", 3/4", 1", 1-1/4", 1-1/2" and 2"

- Strong, portable pin-assembled aluminum components.
- Easy-to-use ram travel scale and bending charts.
- Conduit supports index to suit all sizes.

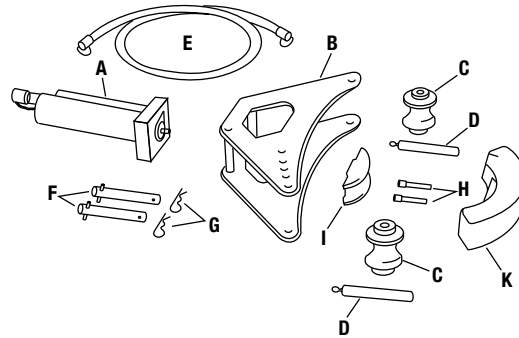

Bending

CAT. NO.	UPC NO.	DESCRIPTION
880	16480	1", 1-1/4", 1-1/2" and 2" Rigid Conduit Bender without hydraulic pump
880H755	16464	1", 1-1/4", 1-1/2" and 2" Rigid Conduit Bender with 755 Hand Hydraulic Pump
880E975	34200	1", 1-1/4", 1-1/2" and 2" Rigid Conduit Bender with 975 Electric Hydraulic Pump
1802	21257	A Bending Table (Optional)
21357	21357	A Conduit Support Pin for use with 1802 Bending Table - (2) Required
10917	10917	A 1/2" Shoe (Optional)
10918	10918	A 3/4" Shoe (Optional)

KEY	CAT. NO.	UPC NO.	DESCRIPTION	880
A	747	16249	15-Ton Hydraulic Ram with 4018GB female quick coupler, includes Keys F, G and one H	1
B	03396	03396	Frame Unit	1
C	03400	03400	Conduit Support	2
D	13679	13679	Conduit Support Pin	2
E	11289	11289	3/8" x 6' (9.5 x 1829 mm) Hydraulic Hose with two 4033GB male quick couplers	1
F	15829	15829	Cylinder Head Pin Unit with Spring Clips 2725AA (Key G)	2
G	50302	50302	Spring Clips	2
H	10826	10826	Ram Pin, Shoe Pin	2
I	10939	10939	Shoe Support	1
K	10919	10919	1" Shoe - Rigid	1
K	10920	10920	1-1/4" Shoe - Rigid	1
K	10921	10921	1-1/2" Shoe - Rigid	1
K	10922	10922	2" Shoe - Rigid	1
	14909	14909	Steel Storage Box (not shown)	1

CENTERLINE BENDING RADII FOR 880 & 880 PVC BENDERS

Rigid Shoe Size	1/2"	3/4"	1"	1-1/4"	1-1/2"	2"
Bending Radius-Inches	4"	4-1/2"	5-3/4"	7-1/4"	8-1/4"	9-1/2"
Bending Radius-cm	10.16	11.43	14.60	18.41	20.95	24.13

SPECIFICATIONS

Capacity	880: 1" - 2" Rigid Conduit
Power Source	755: Hydraulic Hand Pump 975: 120 VAC Electric Hydraulic Pump 980: 120 VAC Electric Hydraulic Pump
Weight	880: 113 lbs. (52 kg) 880H755: 135 lbs. (61 kg) 880E975: 172 lbs. (78 kg)

INTERNATIONAL

Tel: +1.815.397.7070
Fax: +1.815.397.9247

CANADA

Tel: 800.435.0786
Fax: 800.524.2853

USA

Tel: 800.435.0786
Fax: 800.451.2632

Rigid Conduit Bender for 1-1/4" - 2" One-Shot 90°s and 2-1/2" - 4" Segment Bending

- Strong, portable pin-assembled aluminum components.
- Easy-to-use ram travel scale and bending charts.
- Conduit supports index to suit all sizes.

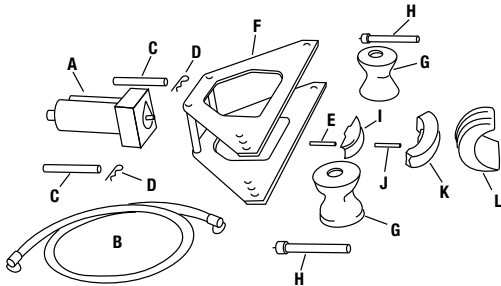

CENTERLINE BENDING RADII FOR 777 BENDERS

Rigid Shoe Size	SEGMENT BEND ONLY						
	1-1/4"	1-1/2"	2"	2-1/2"	3"	3-1/2"	4"
Bending Radius-Inches	7-1/4"	8-1/4"	9-1/2"	11-7/16"	13-3/4"	16"	18-1/4"
Bending Radius-mm	184.1	209.5	241.3	290.5	349.3	406.4	463.6

SPECIFICATIONS

Capacity	1-1/4" - 4" Rigid Conduit
Power Source	755: Hydraulic Hand Pump 975: 120 VAC Electric Hydraulic Pump 980: 120 VAC Electric Hydraulic Pump
Weight	777: 164 lbs. (75 kg) 777HC755: 173 lbs. (79 kg) 777E975: 508 lbs. (231 kg)

CAT. NO.	UPC NO.	DESCRIPTION
777	16491	1-1/4" through 2" One-Shot and 2-1/2" through 4" Segment, Rigid Conduit Bender without hydraulic pump
777HC755	16470	1-1/4" through 2" One-Shot and 2-1/2" through 4" Segment, Rigid Conduit Bender with 755 Hand Hydraulic Pump
777E975	34198	1-1/4" through 2" One-Shot and 2-1/2" through 4" Segment, Rigid Conduit Bender with 975 Electric Hydraulic Pump
1802	21257	A Bending Table (Optional)
21359	21359	A Conduit Support Pin for use with 1802 Bending Table - (2) Required

KEY	CAT. NO.	UPC NO.	DESCRIPTION	777
A	1736	13251	27-Ton Hydraulic Ram with 4018GB female quick coupler, includes Keys C thru E	1
B	11289	11289	3/8" x 6' (9.5 x 1829 mm) Hose with two 4033GB male quick couplers	1
C	13252	13252	Cylinder Head Pin Unit with Spring Clip 2725AA (Key D)	2
D	50302	50302	Spring Clip	2
E	10826	10826	Ram Pin	1
F	13232	13232	Frame Unit	1
G	13193	13193	Conduit Support	2
H	14496	14496	Conduit Support Pin	2
I	10939	10939	Small Shoe Support 1/2" thru 2"	1
J	10826	10826	Shoe Pin	1
K			90° Aluminum Bending Shoes	
	10920	10920	1-1/4" Shoe	1
	10921	10921	1-1/2" Shoe	1
	10922	10922	2" Shoe	1
L			Aluminum Segment Bending Shoes	
	13208	13208	2-1/2" Shoe	1
	13209	13209	3" Shoe	1
	13210	13210	3-1/2" Shoe	1
	13211	13211	4" Shoe	1
M	13382	13382	Steel Storage Box (not shown)	1

Bending

USA

Tel: 800.435.0786
Fax: 800.451.2632

CANADA

Tel: 800.435.0786
Fax: 800.524.2633

INTERNATIONAL

Tel: +1.815.397.7070
Fax: +1.815.397.9247

Rigid Conduit Benders for One-Shot 90°s in 1-1/4" - 4" (5" with Segment Bending Shoe)



Shown with OPTIONAL 1802 Bending Table & OPTIONAL 980 pump

- Strong, yet lightweight, portable, pin-assembled aluminum components.
- Easy-to-use ram travel scale and charts for accurate bends.
- Make elbows, offsets and saddles.
- Both 884 and 885 bend One-Shot 90°s in 1-1/4" - 4" Rigid conduit.
- Optional shoes available to bend PVC-coated Rigid conduit.
- Optional 1802 Bending Table available for easier operation.

SPECIFICATIONS

Capacity	884: 1-1/4" - 4" Rigid conduit. 884PVC: 1-1/4" - 4" 40 mil PVC Coated Rigid Conduit 885: 1-1/4" - 5" Rigid Conduit
Power Source	980: 120 VAC Electric Powered Hydraulic Pump 980-22PS: 220 VAC 50/60 Cycle Electric Powered Hydraulic Pump
Weight	884: 421 lbs. (191 kg) 884E980: 494 lbs. (225 kg) 884PVC: 388 lbs. (176 kg) 885: 449 lbs. (204 kg) 885E980: 527 lbs. (239 kg)

CAT. NO.	UPC NO.	DESCRIPTION
884	16477	1-1/4" through 4" Rigid Conduit Bender, without hydraulic pump
884E980	34209	1-1/4" through 4" Rigid Conduit Bender, with 980 Electric Hydraulic Pump
884PVC	33614	1-1/4", 1-1/2", 2", 3" and 4" PVC Coated Rigid Conduit Bender without hydraulic pump
885	16751	1-1/4" through 4" One-Shot and 5" Segment Rigid Conduit Bender, without hydraulic pump
885E980	34210	1-1/4" through 4" One-Shot and 5" Segment Rigid Conduit Bender, with 980 Electric Hydraulic Pump
1802	21257 ^A	Bending Table (Optional)

Shoes for 40 mil PVC Coated Rigid Conduit on page 125

Rigid Conduit Benders for One-Shot 90°s in 1-1/4" - 4" (5" with Segment Bending Shoe)

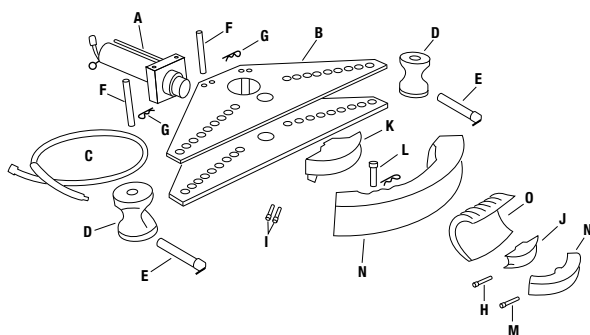

KEY	CAT. NO.	UPC NO.	DESCRIPTION	884	884PVC	885
A	1737	16752	27-Ton Hydraulic Ram with 4018GB female quick coupler, includes Keys F thru I.	1	1	1
B	16754	16754	Frame unit	1	1	1
C	11289	11289	3/8" x 6' (9.5 x 1829 mm) Hydraulic Hose with two 4033GB male quick couplers	1	1	1
D	15671	15671	Conduit Support	2	2	2
	33454	33454	Conduit Support (not shown)		2	
E	16747	16747	Conduit Support pin	2	2	2
F	16753	16753	Cylinder Head Pin Unit with Spring Clip 2725AA	2	2	2
G	50302	50302	Spring Clip	2	2	2
H	25184	25184	Ram Pin	1	1	1
I	10946	10946	Large Ram Pin	2	2	2
J	10939	10939	Small Shoe Support (1/2" through 2")	1	1	1
K	16741	16741	Large Shoe Support (2-1/2" through 4")	1	1	1
L	10963	10963	Large Shoe Pin	1	1	1
M	10826	10826	Small Shoe Pin	1	1	1
	2050	19811	Steel Storage Box (not shown)	1	1	1
N	10920	10920	1-1/4" Shoe - Rigid	1		1
N	10921	10921	1-1/2" Shoe - Rigid	1		1
N	10922	10922	2" Shoe - Rigid	1		1
N	10923	10923	2-1/2" Shoe - Rigid	1		1
N	10924	10924	3" Shoe - Rigid	1		1
N	10925	10925	3-1/2" Shoe - Rigid	1		1
N	14265	14265	4" Shoe - 20" centerline radius - Rigid	1		1
O	15669	15669	5" Shoe - Rigid			1
N	33459	33459	1-1/4" Shoe - PVC		1	
N	33463	33463	1-1/2" Shoe - PVC		1	
N	33462	33462	2" Shoe - PVC		1	
N	34340	34340	3" Shoe - PVC		1	
N	34344	34344	4" Shoe - PVC		1	
	34329	34329	7/8" Wrench (not shown)		1	

884 & 885 CENTERLINE BENDING RADII

SIZE	RIGID	SIZE	PVC RIGID
1-1/4"	7-1/4" (184.1 mm)	1-1/4"	7-1/4" (184.1 mm)
1-1/2"	8-1/4" (209.5 mm)	1-1/2"	8-1/4" (209.5 mm)
2"	9-1/2" (241.3 mm)	2"	9-1/2" (241.3 mm)
2-1/2"	12-1/2" (317.5 mm)	2-1/2"	11-7/16" (290.5 mm)
3"	15" (381 mm)	3"	13-3/4" (349.3 mm)
3-1/2"	17-1/2" (444.5 mm)	3-1/2"	16" (406.4 mm)
4"	20" (508 mm)	4"	18-1/4" (463.5 mm)
5"	25" (635 mm) (885 only)		

Accessories for Bending 40 Mil PVC-Coated Rigid Conduit for 880 and 884 Benders



- Special size shoes and supports for bending 40 mil PVC-Coated Rigid conduit.
- Two conduit supports to fit your bender are required. Shoes for 1-1/2" or larger have a cam device to force the conduit out of the shoe after bending. This requires a wrench to turn the cam.

SHOE UNITS

40 MIL PVC COATED RIGID CONDUIT SIZE			
CAT. NO.	UPC NO.	DESCRIPTION	
33456	33456	Shoe Unit 4" (101.6 mm) Centerline Radius	
33457	33457	Shoe Unit 4-1/2" (114.3 mm) Centerline Radius	
33458	33458	Shoe Unit 5-3/4" (146.1 mm) Centerline Radius	
33459	33459	Shoe Unit 7-1/4" (184.2 mm) Centerline Radius	
33463	33463	Shoe Unit 8-1/4" (209.6 mm) Centerline Radius	
33462	33462	Shoe Unit 9-1/2" (241.3 mm) Centerline Radius	
34321	34321	Shoe Unit 11-7/16" (290.5 mm) Centerline Radius	
34340	34340	Shoe Unit 13-3/4" (349.3 mm) Centerline Radius	
34342	34342	Shoe Unit 16" (406.4 mm) Centerline Radius	
34344	34344	Shoe Unit 18-1/4" (463.6 mm) Centerline Radius	
33455	33455	880 Conduit Support – 2 Required	
33454	33454	884 Conduit Support – 2 Required	
34329	34329	7/8" Wrench. Use with 1-1/2" and larger shoes	

BENDERS / PARTS

CAT. NO.	UPC NO.	DESCRIPTION
884PVC	33614	An 884 Bender with shoes, supports and wrench for bending 1-1/4", 1-1/2", 2", 3" and 4" 40 mil PVC Coated Rigid conduit. In a steel storage box. (See 884 Conduit Bender for details)

Bending Table (only) for 777, 880, 884 and 885 Rigid Conduit Benders



Typical setup with bender (see note)
Shown with 884 Bender and 980 Pump

- Make bending easier, faster and more accurate.
- Insert conduit to be bent in chain vise, tighten. Turn handle to move the chain vise and position conduit for bending.
- Use the Bending Degree Protractor and the movable chain vise to advance conduit while making segment and other multi-shot large sweep bends.
- Includes 1805 Bending Degree Protractor and metal storage box.

CAT. NO. UPC NO. DESCRIPTION

1802	21257	Bending Table - includes pipe support pins for 884 or 885 Benders
21359	21359	A Pipe support Pin for use with 777, 883 and 883-4 Benders, two (2) are required (Optional)
21357	21357	A Pipe Support Pin for use with 880 Bender, two (2) are required (Optional)

NOTE: To complete setup as shown two 10-foot (3.04 m) lengths of 2" Rigid conduit and Bender are required (purchased separately).

PARTS

KEY	CAT. NO.	UPC NO.	DESCRIPTION	1802
A	21541	21541	Leg Support Unit	2
B	21545	21545	Bender Bracket Unit	1
C	1805	21318	Bending Degree Protractor	1
D	21542	21542	Chain Idler Unit	1
E	21543	21543	Crank Bracket Unit	1
F	21544	21544	Pipe Vise Unit	1
G	21360	21360	Pipe Support Pin – 1-1/2" for 884 and 885 Bender	2
H	21413	21413	Chain Extension Kit	1
I	21346	21346	Legs	4
	1531	23274	Steel Storage Box (not shown)	1

SPECIFICATIONS

Capacity	777, 880, 883, 884 and 885 Benders
Weight	180 lbs. (82 kg)

Bending

USA

Tel: 800.435.0786
Fax: 800.451.2632

CANADA

Tel: 800.435.0786
Fax: 800.524.2653

INTERNATIONAL

Tel: +1.815.397.7070
Fax: +1.815.397.9247

BENDER ACCESSORIES

L97 Mini-Magnet Laser Level



- Professional grade laser level.
- Mini-torpedo design with handy “no-dog” attachment for bending.
- Three rare-earth magnets provide superior holding strength.
- Compact size with 80-plus yard range.
- Laser is capable of working on all planes.
- Four vial design - 0°, 90°, 45°, and 30°.
- V-groove on bottom for mounting on curved surface.
- Offsets and calculations permanently laser-engraved onto level.
- Requires (2) “N” style batteries.

CAT. NO.	UPC NO.	DESCRIPTION
L97	03582	Laser, Level

SPECIFICATIONS

Length	5-1/16" (143 mm)	Weight	7.3 oz with batteries
Width	3/4" (19 mm)	Height	1-13/16" (46 mm)

L77 Mini Magnetic Bubble Level



- Professional grade level with bending offset aid.
- Mini torpedo design with handy “no-dog” attachment for bending.
- Three rare-earth magnets provide superior holding strength.
- Four vial design - 0°, 90°, 45°, and 30°.
- Machined from aluminum alloy and anodized to aircraft standards.
- Compact size fits easily in tool pouch.
- V-groove on bottom for mounting on curved surface.

CAT. NO.	UPC NO.	DESCRIPTION
L77	11617	Mini Magnetic Bubble Level

SPECIFICATIONS

Length	5-1/2" (140 mm)
Width	3/4" (19 mm)
Height	1-1/2" (38 mm)

L107 Electrician's Torpedo Level



- Professional grade level.
- Four open vial ports for easy viewing from all sides.
- Perfect for pipe and conduit work.
- Four rare-earth magnets allow for hands-free use on metal surfaces.
- Four vial design - 0°, 30°, 45°, and 90°.
- Machined from aluminum alloy and anodized to aircraft standards.
- V-groove on bottom for mounting on curved surface.
- Offsets and calculations permanently laser-engraved onto level.

CAT. NO.	UPC NO.	DESCRIPTION
L107	03583	Level, Torpedo

SPECIFICATIONS

Length	8-1/2" (215.9 mm)	Weight	5.5 oz
Width	3/4" (19 mm)	Height	1-1/4" (31.8 mm)

Protractor with Magnetic Base



CAT. NO.	UPC NO.	DESCRIPTION
1895	35905	Angle Protractor with Magnetic Base

SPECIFICATIONS

Weight 0.4 lbs. (0.2 kg)

Bending Degree Protractor for use with 1802 and 1813 Bending Tables



- Use to make concentric offset or large-radius bends.
- Bender must be mounted on a bending table . . . and pipe bent in a vertical position.
- Quick-adjusting, chain-type clamp for easy mounting to all conduit and pipe sizes.
- Face of protractor rotates to compensate for any surface that is not level.

CAT. NO.	UPC NO.	DESCRIPTION
1805	21318	Bending Degree Protractor

SPECIFICATIONS

Capacity Protractor face is graduated in quadrants of 18, 20, 21 and 30 shots
Weight 2 lbs. (.91 kg)

Bending Handbook and Slide Rule Bending Calculators



- Bending information on stub-ups, offsets, saddles and concentric bends.
- Pocket size 3-1/2" x 6-3/4".
- Bending charts for Greenlee Benders.
- Easy to use for fast, accurate bending calculations.

CAT. NO.	UPC NO.	DESCRIPTION
38405	38405	Bending Book, English
38409	38409	Bending Book, French
38406	38406	Slide Rule Calculator for 777, 880, 883, 884 and 885 Benders
38407	38407	Slide Rule Calculator for segment bends
38408	38408	Slide Rule Calculator for 881 and 882 Benders

Conduit Size Chart

SIZE	EMT ELECTRICAL METALLIC TUBING						IMC INTERMEDIATE CONDUIT						RIGID CONDUIT STEEL OR ALUMINUM					
	OUTSIDE DIA.		INSIDE DIA.		WALL THICKNESS		OUTSIDE DIA.		INSIDE DIA.		WALL THICKNESS		OUTSIDE DIA.		INSIDE DIA.		WALL THICKNESS	
	INCHES	mm	INCHES	mm	INCHES	mm	INCHES	mm	INCHES	mm	INCHES	mm	INCHES	mm	INCHES	mm	INCHES	mm
1/2"	.706	17.9	.622	15.8	.042	1.1	.815	20.7	.675	17.1	.070	1.8	.840	21.3	.622	15.8	.109	2.8
3/4"	.922	23.4	.824	20.9	.049	1.3	1.029	26.1	.879	22.3	.075	1.9	1.050	26.7	.824	20.9	.113	2.9
1"	1.163	29.5	1.049	26.6	.057	1.5	1.290	32.8	1.120	28.4	.085	2.2	1.315	33.4	1.049	26.6	.133	3.4
1-1/4"	1.510	38.4	1.380	35.1	.065	1.7	1.638	41.6	1.468	37.3	.085	2.2	1.660	42.2	1.380	35.0	.140	3.6
1-1/2"	1.740	44.2	1.610	40.9	.065	1.7	1.883	47.8	1.703	43.3	.090	2.3	1.900	48.3	1.610	40.9	.145	3.7
2"	2.197	55.8	2.067	52.5	.065	1.7	2.360	59.9	2.170	55.1	.095	2.4	2.375	60.3	2.067	52.5	.154	3.9
2-1/2"	2.875	73.0	2.731	69.4	.072	1.8	2.857	72.6	2.597	66.0	.130	3.3	2.875	73.0	2.469	62.7	.203	5.2
3"	3.500	88.9	3.356	85.2	.072	1.9	3.476	88.3	3.216	81.7	.130	3.3	3.500	88.9	3.068	77.9	.216	5.5
3-1/2"	4.000	101.6	3.834	97.4	.083	2.1	3.971	100.9	3.711	94.3	.130	3.3	4.000	101.6	3.548	90.1	.226	5.7
4"	4.500	114.3	4.334	110.1	.083	2.1	4.466	113.4	4.206	106.8	.130	3.3	4.500	114.3	4.026	102.3	.237	6.0
5"	—	—	—	—	—	—	—	—	—	—	—	—	5.563	141.3	5.047	128.2	.258	6.5
6"	—	—	—	—	—	—	—	—	—	—	—	—	6.625	168.3	6.065	154.0	.280	7.1

PVC

PVC Heater Selection Guide

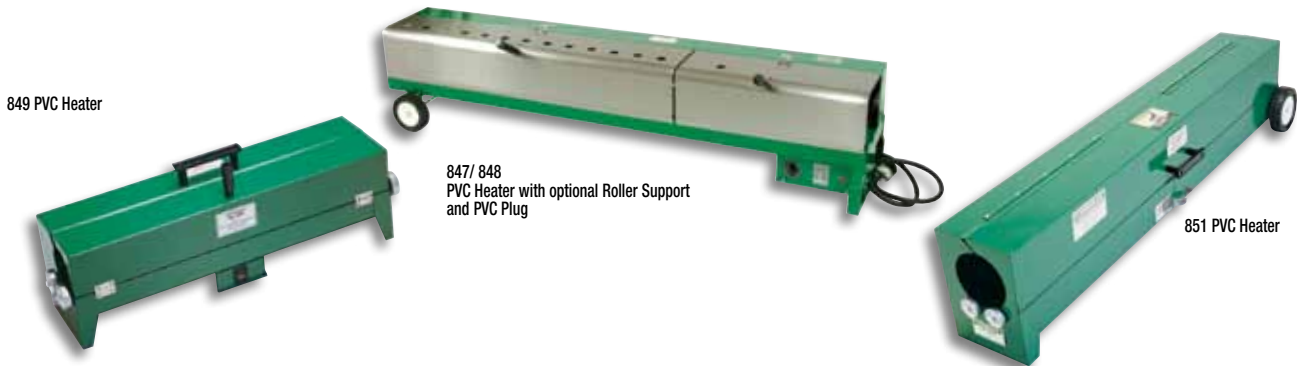

PVC HEATING

CAT. NO. – DESCRIPTION	PAGE NO.	1/2"	3/4"	1"	1-1/4"	1-1/2"	2"	2-1/2"	3"	3-1/2"	4"	5"	6"
860-1-1/2 PVC Heating Blanket	128	✓	✓	✓	✓	✓							
860-3 PVC Heating Blanket	128						✓	✓	✓				
860-4 PVC Heating Blanket	128									✓	✓		
849 PVC Heater	129	✓	✓	✓	✓	✓	✓						
851 PVC Heater	129	✓	✓	✓	✓	✓	✓	✓	✓	✓	✓		
847 / 848 PVC Heater	129	✓	✓	✓	✓	✓	✓	✓	✓	✓	✓	✓	✓

PVC Heating Blankets for up to 4", All Schedules



- Make bends, offsets or saddles in PVC fast and easy.
- Easy to use: wrap blanket around PVC, secure with hook and loop strap. Built-in stiffeners help keep the blanket tight to the PVC surface. Remove blanket and form bend by hand.
- Controlled, even heating for uniform bending.
- Heavy-duty cord and thermostat for long life.
- Temperature over 300° F (149° C).

CAT. NO.	UPC NO.	DESCRIPTION
860-1-1/2	31486	PVC Heating Blanket for up to 1-1/2"
860-3	31487	PVC Heating Blanket for 2"-3"
860-4	31488	PVC Heating Blanket for 3-1/2" and 4"

SPECIFICATIONS

	860-1-1/2	860-3	860-4
Capacity	Up to 1-1/2" PVC All Schedules	2" - 3" PVC All Schedules	3-1/2" - 4" PVC All Schedules
Power Source	120 VAC	120 VAC	120 VAC
Size	13" x 8-1/4" (330.2 x 209.6 mm)	30" x 13-1/4" (762.0 x 336.6 mm)	38" x 16-1/4" (965.2 x 412.8 mm)
Weight	1.7 lbs. (.8 kg)	3.3 lbs. (1.5 kg)	4.9 lbs. (2.2 kg)
Wattage	200	800	1300

Bending

INTERNATIONAL

Tel: +1.815.397.7070
Fax: +1.815.397.9247

CANADA

Tel: 800.435.0786
Fax: 800.524.2853

USA

Tel: 800.435.0786
Fax: 800.451.2632

Electric PVC Heater for 1/2" - 2", All Schedules



120 VAC
20 AMP

- Easy to use: preheat for 10 minutes, insert PVC, rotate until pliable, remove and form bend.
- Sturdy double wall metal with fiberglass insulation and reflective interior for fast, even heat.
- Full length door for easy PVC loading and removal.
- Other features include on/off switch, pilot light and carrying handle.
- Heats 24" Long section of pipe.

CAT. NO.	UPC NO.	DESCRIPTION
849	27395	Electric PVC Heater for 1/2" - 2"
27811	27811	R Calrod Heating Element

SPECIFICATIONS

Capacity	1/2" - 2" PVC All Schedules
Power Source	120 VAC 20 Amp or 3000 Watt Generator
Weight	15 lbs. (6.8 kg)

Electric PVC Heater for 1/2" - 4", All Schedules



120 VAC
20 AMP

- Easy to use: preheat for 10 minutes, open lid and position PVC, close lid, rotate until pliable, open lid, remove PVC and form bend.
- Heavy-duty, insulated metal walls and cover with reflective interior for efficient, even heat.
- Full-length door for easy loading and unloading.
- On/off switch with indicator light.
- Sturdy wheels for easy mobility.
- Use two units in tandem to heat large sweep bends.
- Heats 50" Long section of pipe.

CAT. NO.	UPC NO.	DESCRIPTION
851	35577	Electric PVC Heater for 1/2" - 4"
35592	35592	R Calrod Heating Element

SPECIFICATIONS

Capacity	1/2" - 4" PVC All Schedules
Power Source	120 VAC 20 Amp or 3600 Watt Generator
Length	52" (1321 mm)
Weight	53 lbs. (24 kg)
Wattage	2300

See below for 2" - 4" PVC plugs or 859-4 Plug Set.

Electric PVC Heater for 1/2" - 6", All Schedules



230 VAC
30 AMP

- Easy to use: preheat for 10 minutes, open lid and position PVC, close lid, rotate until pliable, open lid, remove PVC and form bend. 848 model has motorized rotation.
- Heavy-duty metal construction with reflective interior for fast, efficient heating.
- Has heating chart, timer, and on/off switch with indicator light for added convenience.
- Double doors with piano hinges allow heating shorter lengths with one door open.
- Sturdy wheels for easy mobility.
- Heats 65" Long section of pipe.

CAT. NO.	UPC NO.	DESCRIPTION
847	30866	Electric PVC Heater for 1/2"-6" All Schedules
848	30867	Electric PVC Heater with Motorized PVC Rotation for 1/2"-6" All Schedules
31092	31092	A Motorized PVC rotation kit for 847
857	31093	A PVC Roller Support (Optional)
30908	30908	R Calrod Heating Element

SPECIFICATIONS

Capacity	1/2" - 6" PVC All Schedules
Power Source	230 VAC 30 AMP or 7000 Watt Generator
Length	71" (1803 mm)
Weight	847 - 78 lbs. (36 kg) 848 - 80 lbs. (37 kg)
Wattage	6600

PVC ACCESSORIES

PVC Plugs and Plug Set



- Use with PVC Heating Blankets or Electric Heaters to plug the ends of the PVC being heated. The trapped air will help keep the PVC from collapsing while forming the bend.
- Use on Schedule 40 and 80 PVC.
- Available in 2" - 4" set or individual sizes 2" - 6". Order two, one for each end of the PVC.

SPECIFICATIONS

Capacity	2" - 6" PVC Schedules 40 and 80
Weight	859-4 - 8 lbs. (3.6 kg)
	30976 - .3 lbs. (0.2kg)
	30977 - .4 lbs. (0.2 kg)
	30978 - .4 lbs. (0.2 kg)
	30979 - .6 lbs. (3.6 kg)
	30980 - 1 lbs. (0.5 kg)
	30981 - 1.3 lbs. (0.6 kg)

CAT. NO. UPC NO. DESCRIPTION

859-4	35740	PVC Plug Set for 2" - 4". Includes 2 each of 2", 2-1/2", 3" and 4" plugs and carrying case. Case has a place for optional 5" and 6" sizes.
30976	30976	R 2" PVC Plug
30977	30977	R 2-1/2" PVC Plug
30978	30978	R 3" and 3-1/2" PVC Plug
30979	30979	R 4" PVC Plug
30980	30980	R 5" PVC Plug
30981	30981	R 6" PVC Plug
31228	31228	R Plastic Carrying Case

PVC Cutter



- Cuts 3/4" schedule 40 PVC
- Cuts 1/8" - 1-3/8" (3-35mm) O.D. flexible plastic pipe
- Diecast aluminum alloy body for added strength and blade guide for square cuts.
- Reversible blade for twice the life.
- Handle latch for safety.

CAT. NO. UPC NO. DESCRIPTION

862	89806	Plastic Pipe Cutter
-----	-------	---------------------

SPECIFICATIONS

Capacity	Up through 1-3/8" O.D. Flexible Plastic Pipe
Weight	0.36 lbs. (0.16 kg)

PVC Cutter for up to 1-1/4"



- Ratchet action for fast, easy cutting.
- Heat-treated, replaceable steel blade for long cutting life.
- Rugged metal alloy frame for durability.

CAT. NO. UPC NO. DESCRIPTION

864	04253	PVC Cutter for up to 1-1/4"
00355	00355	R Blade Kit

SPECIFICATIONS

Capacity	Up thru 1-1/4" PVC
Weight	0.8 lbs. (0.4 kg)

PVC Cutter for up to 2"



- High-leverage compound ratchet action and long handles reduce effort.
- Heavy-duty metal frame for cutting large diameters.
- Sharpenable and replaceable tool steel blade.

CAT. NO. UPC NO. DESCRIPTION

865	09865	PVC Cutter for up to 2"
07978	07978	R Blade

SPECIFICATIONS

Capacity	Up thru 2" PVC
Weight	2.5 lbs. (1.1 kg)